

Compact-THERM SVE Systems



EQUIPMENT FEATURES

Compact-THERM remediation systems are powerful 500 -700 scfm thermal and catalytic systems mounted onto a 6-ft x 6-ft skid. They offer the ultimate in performance, and our powerful Jet-THERM burner for the lowest operating costs possible.

Skid Size: The skid size is 6-ft x 6-ft, with mounting lugs. Weight is approximately 4000# with stack.

SVE Extraction Blower: The standard SVE Blower is a Roots 59 with 10-20 hp TEFC motor, rated for 500 cfm and vacuums to 14" Hg. Larger flows and options are available.

Controls: **Compact-THERM** systems come complete with Nema 4 control panel, PLC with digital message display, color digital recorder, temperature controllers (2), UV flame safeguard system, safety interlocks, natural gas train, air flow transmitter, and hour meter.

Stainless Water KO & AutoPump: 60-gallon water capacity with level switch controlled pump.

Jet-THERM Burner: All stainless steel high performance burner with up to 100:1 turndown ratio, high energy efficiency, and 3-yr warranty.

OPTIONS

- Catalyst
- Heat Exchanger
- Hi-Flow SVE Blower: 370 cfm, 10" Hg
- Dual Phase Extraction Blower
- High Vacuum SVE Blower
- Internet Access Telemetry & Control
- Enclosure
- LEL & Oxygen Sensor Monitors



SOIL-THERM
EQUIPMENT, INC.

5310 Derry Ave, Unit C
Agoura Hills, CA 91301-4509
(818) 706-2145 FAX (818) 706-2145

www.soiltherm.com

Compact-THERM Remediation Systems

Each **Compact-THERM** thermal system includes the following components 6-ft x 6-ft heavy duty skid with forklift pockets, electric heater with SCR controller, stainless steel water knockout, stainless steel vapor piping, water knockout filter element, Nema 4 electrical control box, main disconnect, positive displacement SVE extraction blower (standard 20 hp, 500 cfm, 14" Hg), PLC control and digital display, hour meter, temperature and limit controller, air pressure switch, flame arrestor, and safety interlocks. Options include: pressure side dilution air blower, open or enclosed trailer, water knockout pump, dual phase liquid ring pump, other SVE blowers, and locking enclosure.

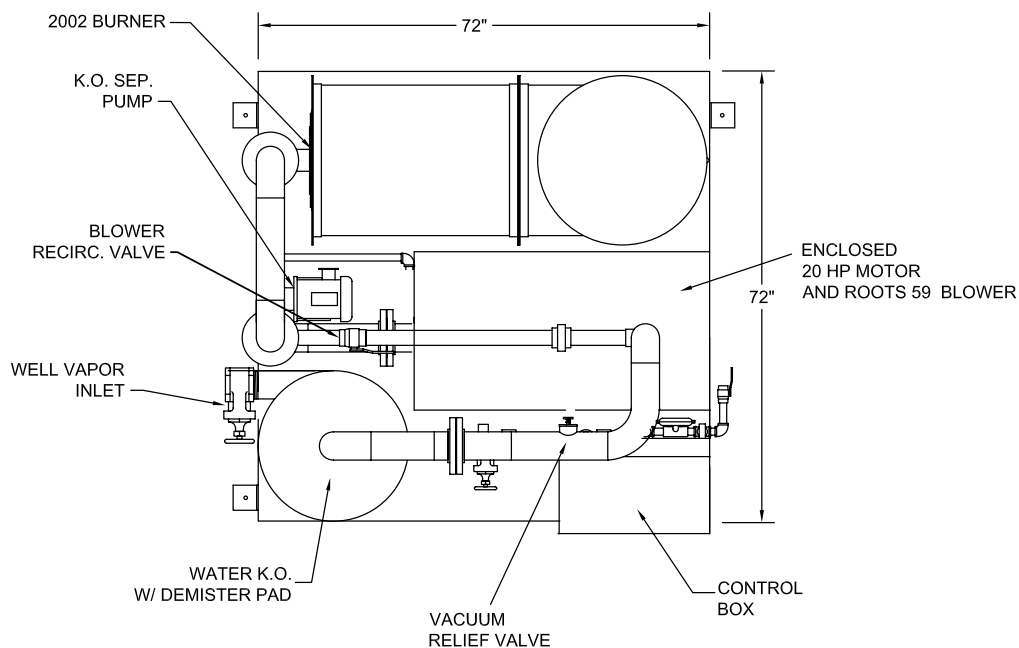

Equipment Specifications

VOC Processing: to 12,000 ppmv
 Destruction Efficiency: >99%
 VOC's /hour (max): 110 #/hour
 Size: 6-ft x 6-ft x 13-ft (H)
 Weight: ~4000 lbs
 Well Vapor Connect: 4"

Electrical: 230VAC, 3-phase, 60Hz
 (phase converters available)
 Natural Gas: 3/4", 300 cfm @ 2-5 psig
 Propane: 3/4", 150 cfm @ 2-5 psig vapor
 Stack Height: 13-ft

Approvals: UL 508A Certified Panel
 SCAQMD Certified Permit



SOIL-THERM
EQUIPMENT, INC.

5310 Derry Ave, Unit C
 Agoura Hills, CA 91301-4509
 (818) 706-2145 FAX (818) 706-2145

www.soiltherm.com