

Mini-THERM SVE Systems



Mini-THERM
5-ft x 5-ft skid



EQUIPMENT FEATURES

With a footprint of only 5' x 5', these soil-vapor-extraction thermal systems are able to remove up to 400 cfm in thermal or catalytic modes, and out-perform other systems.

Skid Size: The skid size is only 5-ft x 5-ft, with mounting lugs. Weight is approximately 3000 lbs with stack.

SVE Extraction Blower: The standard SVE Blower is a Roots 56 with 10 hp TEFC motor, rated for 220 cfm and vacuums to 14" Hg. Larger flows and options are available.

Controls: *Mini-THERM* systems come complete with Nema 4 control panel, PLC with digital message display,

Stainless Water KO & AutoPump: 40-gallon water capacity with level switch controlled pump.

Jet-THERM Burner: All stainless steel high performance burner with up to 100:1 turndown ratio, high energy efficiency, and 3-yr warranty. Patented combustion technology.

OPTIONS

- ReMAC** - Remote Monitoring and Control
- Analogs: Press., Temp, Flows, Vacuum & more
- Catalyst
- Heat Exchanger
- Dual Phase Extraction Blower
- High Vacuum SVE Blower
- LEL & Oxygen Sensor Monitors
- Trailer
- Enclosure

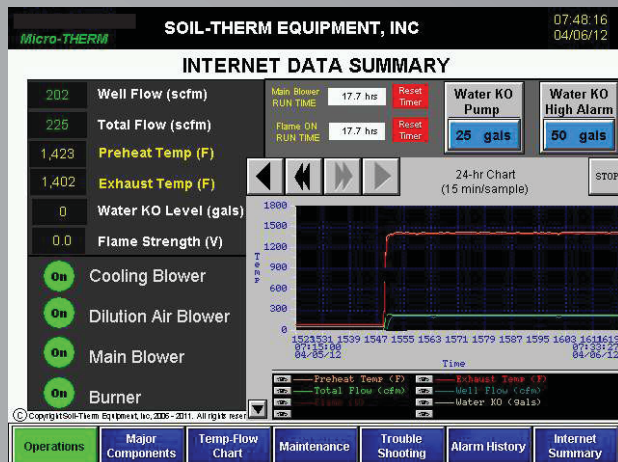

5310 Derry Ave, Unit C
Agoura Hills, CA 91301-4509
(818) 706-2145 FAX (818) 706-2145

www.soiltherm.com

Mini-THERM Remediation Systems

Each **Mini-THERM** Remediation System includes the following components 5-ft x 5-ft heavy duty skid with forklift pockets, patented *Jet-THERM* burner, stainless steel water knockout, stainless steel vapor piping, Nema 4 electrical control box, main disconnect, regenerative SVE extraction blower (standard 10 hp, 300 cfm, 14" Hg), PLC control and digital display, hour meter, temperature and limit controller, air pressure switch, flame arrestor, and safety interlocks. Options include: catalyst module, heat exchanger, pressure side dilution air blower, small single axle trailer, water knockout pump, dual phase liquid ring pump, other SVE blowers, and locking enclosure.

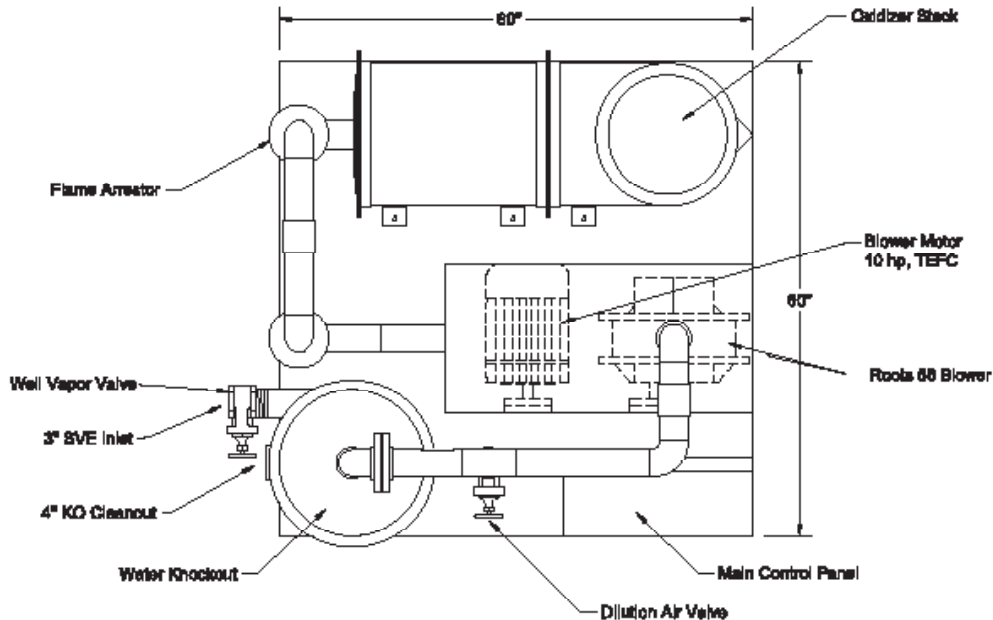

Equipment Specifications

VOC Processing: to 12,000 ppmv
 Flow Range: 100 - 450 cfm
 Destruction Efficiency: Greater than 99%
 VOC's /hour (max): 35 lbs/hour
 Size: 5-ft x 5-ft x 13-ft (H)
 Weight: ~3500 lbs
 Well Vapor Connect: 3"

Electrical: 230VAC, 3-phase, 60Hz, 60A
 (phase converters available)
 Natural Gas: 3/4", 700 cfh @ 2-5 psig
 Propane: 3/4", 300 cfh @ 2-5 psig vapor
 Stack Height: 13-ft

Approvals: UL 508A Certified Panel
 SCAQMD Certified Permit



SOIL-THERM
EQUIPMENT, INC.

5310 Derry Ave, Unit C
 Agoura Hills, CA 91301-4509
 (818) 706-2145 FAX (818) 706-2145

www.soiltherm.com